

SAW Mounting (Rectangular)

Rectangular SAW mountings are also known as 'Sandwich' mountings because they feature a rubber section sandwiched between plates of metal.

This arrangement allows a large difference between the compression and shear stiffnesses, thus providing the potential to 'tune' a mounting system by rotating the mountings.

The Rectangular SAW Mountings have the following features:

- Available with plate or stud fixings
- Can be loaded in compression or shear, or a combination of both, for example in a 'Vee' arrangement
- Can be manufactured with or without interleaves to change the ratio of shear to compression stiffness

Typical Applications Include:

- Low frequency machinery
- Vibratory screens
- Crushing equipment
- Engine mounts



TECHNICAL DRAWING

PLATE FIXING

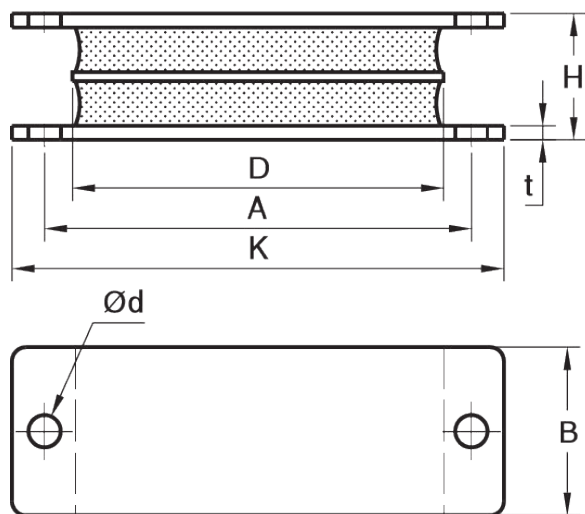

BOLT FIXING

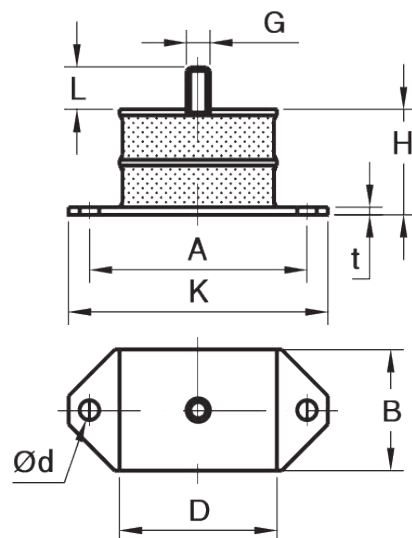

SAW Mounting (Rectangular)

PRODUCT DATA

DRAWING NO.	PART NO.	TYPE	DIMENSIONS (mm)								MAX. LOAD (Kg)		STIFFNESS (N/mm)		
			A	B	K	H	D	Ød	t	Offsets	COMPRESSION	SHEAR	COMPRESSION	SHEAR	
SAW (RECTANGULAR PLATE FIXING)															
31-0322	10-00658	45 °IRHD	89	57	108	43	63.5	11	5	-		180	50	895	36
	10-00659	60 °IRHD										360	75	1530	72
31-0242	10-00648	45 °IRHD	146	57	168	43	127	11	5	-		450	120	1765	80
	10-00651	60 °IRHD										900	150	3408	160
	10-00652	70 °IRHD										1050	150	6343	240
31-0285	10-00656	45 °IRHD	14	57	168	43	127	11	5	-		275	150	767	72
	10-00657	60 °IRHD										546	150	1655	144
051 18 004	96787	45 NR 11	146	57	168	51	117.5	10.8	4	11		140	110	400	70
	96788	55 NR 11										280	190	800	130
	96789	60 NR 11										306	200	870	150
	96790	70 NR 11										470	220	1340	200
051 18 723	49038296	60NR11	295	112	322	90	-	14	8	12	800	550	2700	460	
051 18 002	96791	45 NR 11	146	57	168	43.2	127	10.8	4	-		740	170	2740	130
	96793	55 NR 11										900	220	3330	200
	96792	65 NR 11										1510	240	5590	240
	96794	70 NR 11										1890	300	7000	380
051 18 719	49002463	60 NR 11	-	110	290	50	240	-	10	-	2500	580	12500	480	
051 18 720	49002649	45 NR 11	235	170	255	49	140	9	6	-		4100	400	20500	500
	49002650	60 NR 11										9800	750	49000	940

DRAWING NO.	PART NO.	TYPE	DIMENSIONS (mm)									MAX. LOAD (kg)		STIFFNESS (N/mm)	
			A	B	K	H	ØD	Ød	t	G	L	COMPRESSION	SHEAR	COMPRESSION	SHEAR
SAW (RECTANGULAR BOLT FIXING)															
31-0406	10-00661	45 °IRHD	74.5	41	89	36	54	6.5	2.5	M8	14	90	40	290	29
	10-00971	60 °IRHD										180	70	560	57
	10-00663	70 °IRHD										250	90	832	85
051 18 001	96796	45 NR 11	75	41	90	35.8	54	6.5	2.5	M8	14	120	44	500	40
	96797	50 NR 11										150	50	630	50
	96798	60 NR 11										230	60	960	80
	96745	70 NR 11										300	80	1250	110