

SCHWINGMETALL® Topfelemente

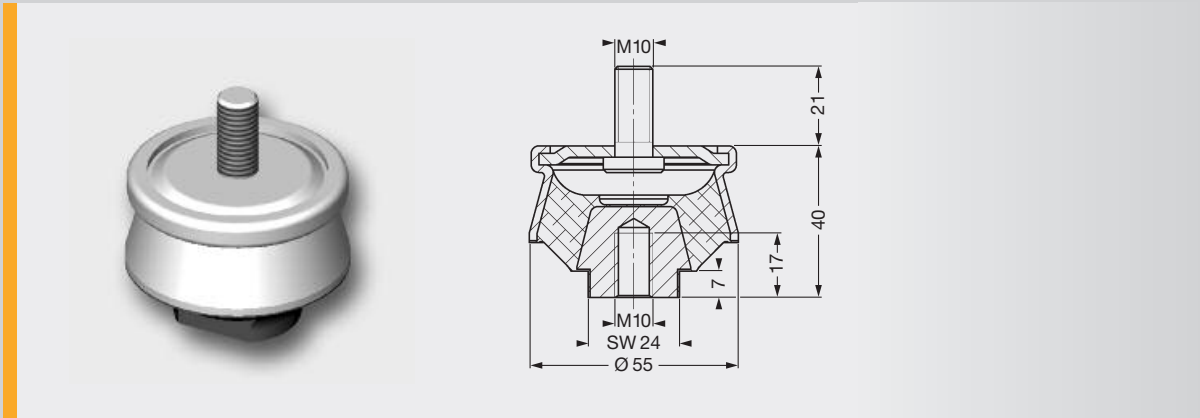

Form-Nr. 104169

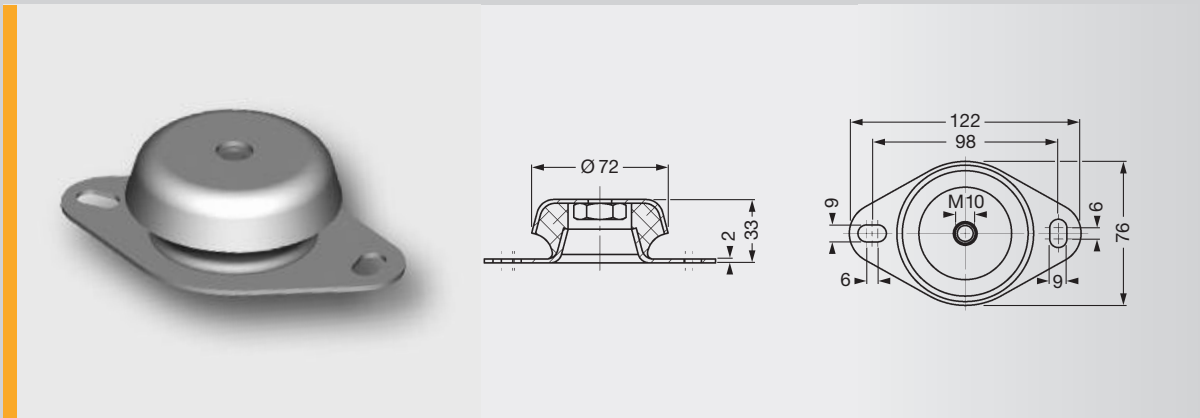

Form-Nr. 103965

Topfelemente										
Abmessungen										
a [mm]	b [mm]	d1 [mm]	d2 [mm]	e [mm]	g [mm]	h [mm]	s1 [mm]	s2 [mm]	s3 [mm]	Scheibe DIN 9021-ST
□ 88	□ 108	101	4 x 9	SW8	M12	40	3	2,5	5	A13x3
□ 88	□ 108	101	4 x 9	SW8	M12	40	3	2,5	5	A13x3
□ 88	□ 108	101	4 x 9	SW8	M12	40	3	2,5	5	A13x3
□ 132	□ 168	136	4 x 13	SW10	M16	50	4	3,0	6	A17x3
□ 132	□ 168	136	4 x 13	SW10	M16	50	4	3,0	6	A17x3
□ 132	□ 168	136	4 x 13	SW10	M16	50	4	3,0	6	A17x3
□ 165	□ 200	192	4 x 13	SW14	M20	70	6	4,0	6	A21x4
□ 165	□ 200	192	4 x 13	SW14	M20	70	6	4,0	6	A21x4
□ 165	□ 200	192	4 x 13	SW14	M20	70	6	4,0	6	A21x4

- ▶ Vor der Montage der Unterlegmatte die Noppen mit Seifenwasser anfeuchten
- ▶ Muttern nach DIN 555, Scheiben nach DIN 125 und Federringe nach DIN 127 sind handelsübliche Teile

Belastungsrichtungen

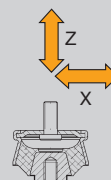

Belastungsrichtungen

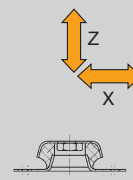

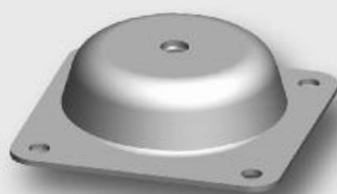

Form-Nr. 58540, 33629, 58541

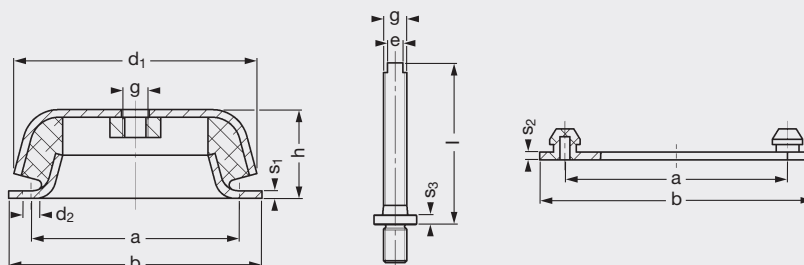

Form-Nr. 58540, 33629, 58541

Federsteifigkeiten			max. Belastungen			Masse Stück [kg]	Elastomer Härte [Shore A]	Form-Nr.	Artikel-Nr. Lager	Artikel-Nr. Nivellier- spindel	Artikel-Nr. Unterleg- matte
C_x [N/mm]	C_y [N/mm]	C_z [N/mm]	F_x [N]	F_y [N]	F_z [N]						
221	221	110	200	200	400	0,248	40	104169	3956412001		
437	437	200	410	410	687	0,248	55	104169	3956212001		
730	730	316	650	650	1080	0,248	65	104169	3956112001		
180	180	405	300	300	1965	0,238	40	103965	3956410000		
320	320	605	480	480	2450	0,238	55	103965	3956210000		
460	460	981	690	690	2950	0,238	65	103965	3956110000		
410	410	505	900	900	1965	0,650	40	58540	3956406000	3956026000	3956016000
746	746	910	1650	1650	3500	0,650	55	58540	3956206000	3956026000	3956016000
1180	1180	1315	2600	2660	4950	0,650	65	58540	3956106000	3956026000	3956016000
850	850	920	1750	1750	4000	1,770	40	33629	3956405000	3956025000	3956015000
1540	1540	1650	3300	3300	6900	1,770	55	33629	3956205000	3956025000	3956015000
2400	2400	2555	5000	5000	9850	1,770	65	33629	3956105000	3956025000	3956015000
1400	1400	1390	4200	4200	7900	4,215	40	58541	3956407000	3956027000	3956017000
2400	2400	2250	7000	7000	12000	4,215	55	58541	3956207000	3956027000	3956017000
3450	3450	3400	10350	10350	19700	4,215	65	58541	3956107000	3956027000	3956017000

Belastungsrichtungen

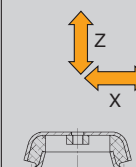

SCHWINGMETALL® Topfelemente

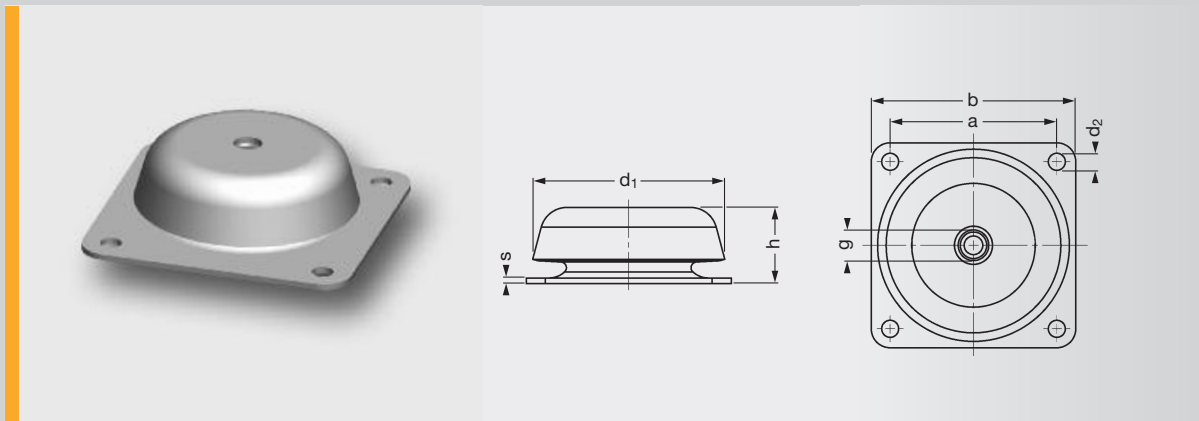

Topfelemente Serie AS						
Abmessungen						
a [mm]	b [mm]	d1 [mm]	d2 [mm]	g [mm]	h [mm]	s [mm]
□ 88	□ 108	101	4 x 9	M12	40	3
□ 88	□ 108	101	4 x 9	M12	40	3
□ 88	□ 108	101	4 x 9	M12	40	3
□ 132	□ 168	136	4 x 13	M16	50	4
□ 132	□ 168	136	4 x 13	M16	50	4
□ 132	□ 168	136	4 x 13	M16	50	4

► Das Lager hat einen integrierten Zuganschlag

Federsteifigkeiten			max. Belastungen			Masse Stück [kg]	Elastomer Härte [Shore A]	Form-Nr.	Artikel-Nr.
C_x [N/mm]	C_y [N/mm]	C_z [N/mm]	F_x [N]	F_y [N]	F_z [N]				
410	410	505	900	900	1965	0,65	40	210642	4000005311
746	746	910	1650	1650	3500	0,65	55	210642	4000005312
1180	1180	1315	2600	2660	4950	0,65	65	210642	4000005313
850	850	920	1750	1750	4000	1,77	40	210643	4000005314
1540	1540	1650	3300	3300	6900	1,77	55	210643	4000005315
2400	2400	2555	5000	5000	9850	1,77	65	210643	4000005316

Passende Unterlegmatten und Nivellierspindeln

◀ siehe Seite 40

Belastungsrichtungen

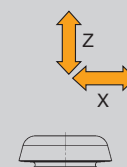

SCHWINGMETALL® Topfelemente

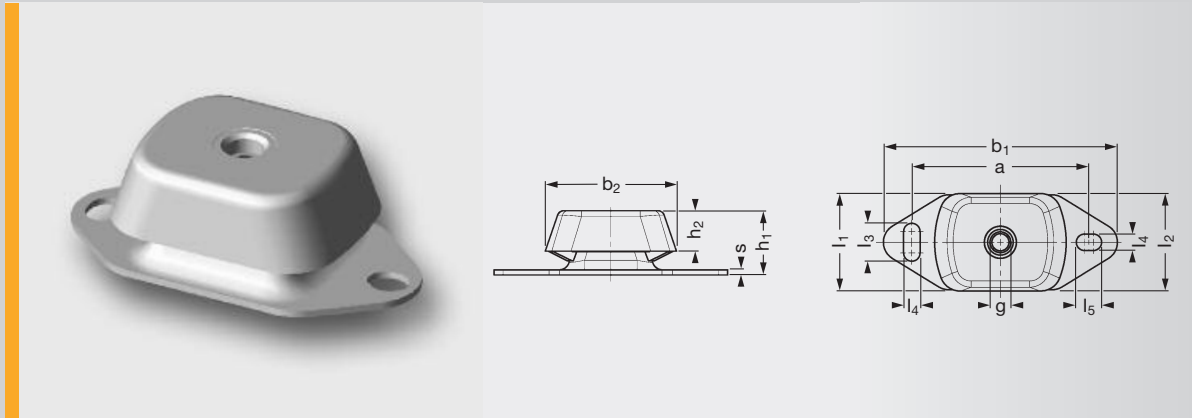

Topfelemente Serie C											
Abmessungen											
a [mm]	b1 [mm]	b2 [mm]	g [mm]	h1 [mm]	h2 [mm]	l1 [mm]	l2 [mm]	l3 [mm]	l4 [mm]	l5 [mm]	s [mm]
100	120	80,0	M12	39	24,0	60	60	14	11	14	2,5
100	120	80,0	M12	39	24,0	60	60	14	11	14	2,5
100	120	80,0	M12	39	24,0	60	60	14	11	14	2,5
140	185	104,0	M16	50	31,5	75	77	30	13	20	4,0
140	185	104,0	M16	50	31,5	75	77	30	13	20	4,0
140	185	104,0	M16	50	31,5	75	77	30	13	20	4,0
182	228	131,5	M20	70	50,0	114	114	34	18	26	5,0
182	228	131,5	M20	70	50,0	114	114	34	18	26	5,0
182	228	131,5	M20	70	50,0	114	114	34	18	26	5,0

► Das Lager hat einen integrierten Zugenschlag

Federsteifigkeiten			max. Belastungen			Masse Stück [kg]	Elastomer Härte [Shore A]	Form-Nr.	Artikel-Nr.
C_x [N/mm]	C_y [N/mm]	C_z [N/mm]	F_x [N]	F_y [N]	F_z [N]				
250	180	90	290	90	300	0,40	45	210620	4000004903
320	210	120	310	120	400	0,40	55	210620	4000004904
480	330	170	500	180	600	0,40	65	210620	4000004905
430	120	220	780	140	1100	0,95	45	210621	4000004906
680	240	320	1200	160	1600	0,95	55	210621	4000004907
800	530	445	1500	260	2200	0,95	65	210621	4000004908
940	370	620	2700	380	3600	2,25	45	210622	4000004909
1100	630	820	3300	680	5000	2,25	55	210622	4000004920
1250	810	1150	3800	800	5900	2,25	65	210622	4000004921

Passende Nivellierspindeln
 ◀ siehe Seite 40

Belastungsrichtungen

