

SCHWINGMETALL® Flanschelemente

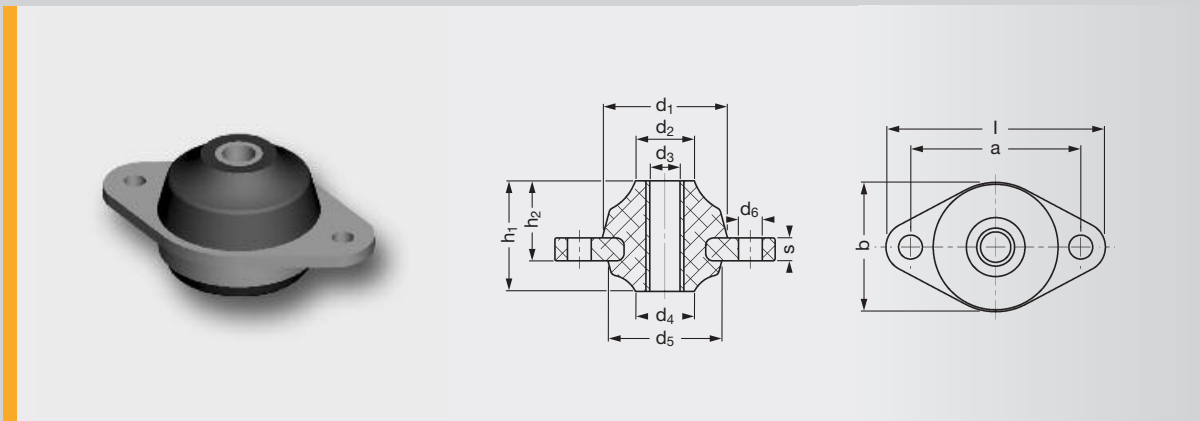

Flanschelemente											
Abmessungen											
a [mm]	b [mm]	d1 [mm]	d2 [mm]	d3 [mm]	d4 [mm]	d5 [mm]	d6 [mm]	h1 [mm]	h2 [mm]	l [mm]	s [mm]
45	34	33	15,5	8	15,5	—	6,3	29	21	58	6 ¹⁾
70	48	47	23,0	12	22	—	9	40	28	90	8 ¹⁾
94	71	68	33,0	16	37	65	9	54	33	117	5
94	71	68	39,0	16	37	65	9	49	28	117	5
94	71	68	52,0	16	48	65	9	44	21	117	5
114	90	82	40,0	20	42	80	13	68	40	150	6
114	90	82	49,0	20	42	80	13	62	34	150	6
114	90	82	60,0	20	53	80	13	51	23	150	6
138	108	96	45,0	20	47	95	13	82	46	174	8
138	108	96	58,0	20	47	95	13	76	40	174	8
138	108	96	62,0	20	63	95	13	68	29	174	8

¹⁾ Kunststoff-Flansch

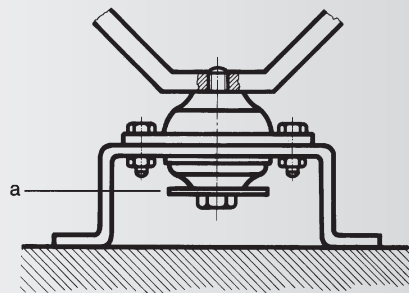
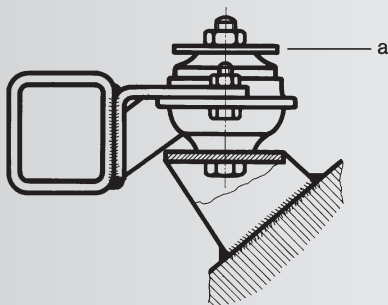

Einbaubeispiele – Die statische Last wirkt in beiden Fällen auf den höheren Federkörper

► Montagehinweis

Zur Funktionserfüllung sind die in den beiden Einbaubeispielen skizzierten Scheiben a erforderlich, gehören aber nicht zum Lieferumfang. Der Durchmesser der Scheiben darf $d_1 - 5$ mm nicht unterschreiten. Der Durchmesser der Durchgangsschraube muss kleiner als d_3 sein.

Federsteifigkeiten		max. Belastungen		max. Stoßbelastungen ²⁾		Masse	Elastomer Härte [Shore A]	Form-Nr.	Artikel-Nr.
C _{x,y} [N/mm]	C _z [N/mm]	F _{x,y} [N]	F _z [N]	F _{Stoß X,Y} [N]	F _{Stoß Z} [N]	Stück [kg]			
153	83	160	600	400	+700 / -1500 ³⁾	0,026	45	48684	■
237	125	280	700	400	+1500 / -2000 ³⁾	0,080	45	48685	■
227	140	720	1200	1800	+2500 / -5000	0,395	45	48686	■
273	245	720	1200	1800	+2500 / -5000	0,384	45	48687	■
307	356	720	1200	1800	+2500 / -5000	0,380	45	48688	■
290	158	1120	1800	2800	+5000 / -7500	0,785	45	48689	■
410	280	1120	1800	2800	+5000 / -7500	0,768	45	48690	■
550	435	1120	1800	2800	+5000 / -7500	0,730	45	48691	■
456	228	1800	2400	4500	+7500 / -10000	1,570	45	48692	■
460	247	1800	2400	4500	+7500 / -10000	1,540	45	48693	■
559	380	1800	2400	4500	+7500 / -10000	1,490	45	48694	■

²⁾ Maximale Stoßbeanspruchung unter Nennlast.

■ Anfertigungsware

³⁾ Bei Stoßbeanspruchung ist eine gute Abstützung der Kunststoff-Flansche erforderlich.

Belastungsrichtungen

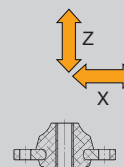

SCHWINGMETALL® Flanschelemente

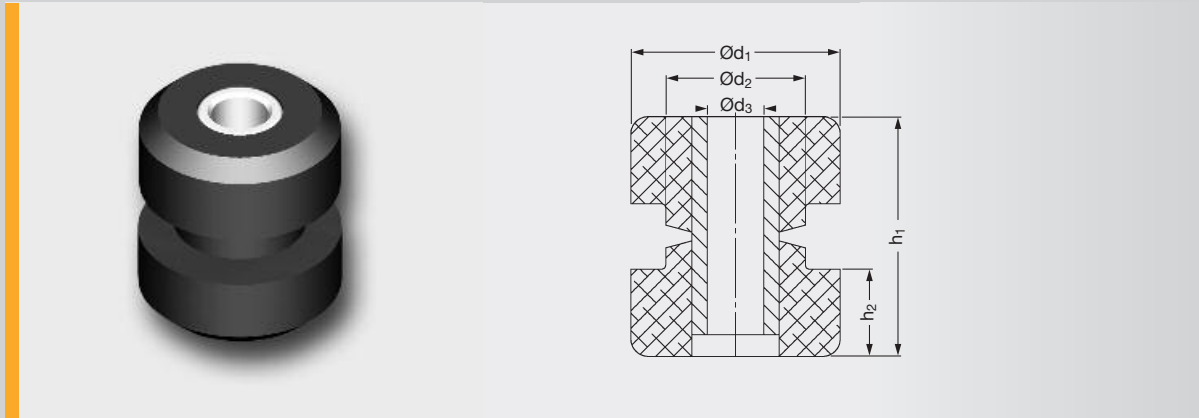

Flanschelemente Serie B										
Abmessungen										
d1 [mm]	d2 [mm]	d3 [mm]	d4 [mm]	d5 [mm]	h1 [mm]	h2 [mm]	h3 [mm]	s [mm]	r [mm]	g
48	32	13	min. 55	31	53	20	50	15	1,5	M12
48	32	13	min. 55	31	53	20	50	15	1,5	M12
48	32	13	min. 55	31	53	20	50	15	1,5	M12
64	40	17	min. 70	39	65	23	62	22	2,3	M16
64	40	17	min. 70	39	65	23	62	22	2,3	M16
64	40	17	min. 70	39	65	23	62	22	2,3	M16
88	57	24	min. 95	56	76	25	73	28	3	M20
88	57	24	min. 95	56	76	25	73	28	3	M20
88	57	24	min. 95	56	76	25	73	28	3	M20

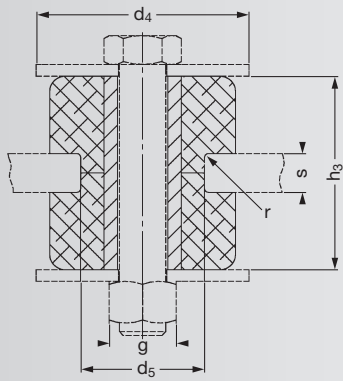

Federsteifigkeiten		max. Belastungen F_z [N]	Masse Stück [kg]	Elastomer Härte [Shore A]	Form-Nr.	Artikel-Nr.
$C_{x,y}$ [N/mm]	C_z [N/mm]					
260	410	400	0.150	40	210670	4000005278
380	670	900	0.150	55	210670	4000005279
540	950	1200	0.150	65	210670	4000005301
330	670	1300	0.275	40	210671	4000005302
500	1060	2100	0.275	55	210671	4000005303
690	1370	2900	0.275	65	210671	4000005304
410	1050	1700	0.600	40	210672	4000005305
720	1760	3400	0.600	55	210672	4000005306
1000	2320	4600	0.600	65	210672	4000005307

Belastungsrichtungen

