

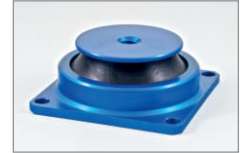

EluFlex® 180-1000 SF Datenblatt



Technische Spezifikationen Technical specifications

Stand Status: 12/06/2015

Artikelnummer Article number

920207

Werkstoffe Materials

Metalle:

■ Aluminiumlegierung AlMgSi1 (EN AW-6082) blau eloxiert 20µm
- seewassergeeignet nach DIN 81249-1

Metals:

■ Aluminium alloy AlMgSi1 (EN AW-6082) blue anodised 20µm
- Brine-resistant per DIN 81249-1

Elastomer:

■ NR (Naturkautschuk)
- Eigenschaften siehe Datenblatt „Werkstoffeigenschaften Gummi“ auf www.sd-dresden.de

Elastomer:

■ NR (natural rubber)
- For characteristics see „Rubber material characteristics“ on www.sd-dresden.de

Technische Zeichnung Technical drawing

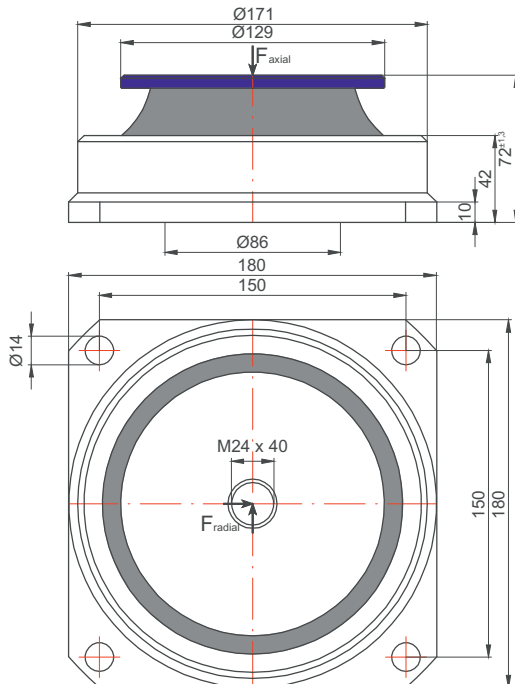

Die Angaben für Federeigenschaften und Eigenfrequenzverlauf sind Anhaltswerte und können aufgrund der Fertigungstoleranz der Elastomere etwas abweichen.
The information provided in relation to spring characteristics and the resonant frequency course constitutes reference values and may deviate slightly, depending on the production tolerance of the elastomer.

Federeigenschaften Spring characteristics

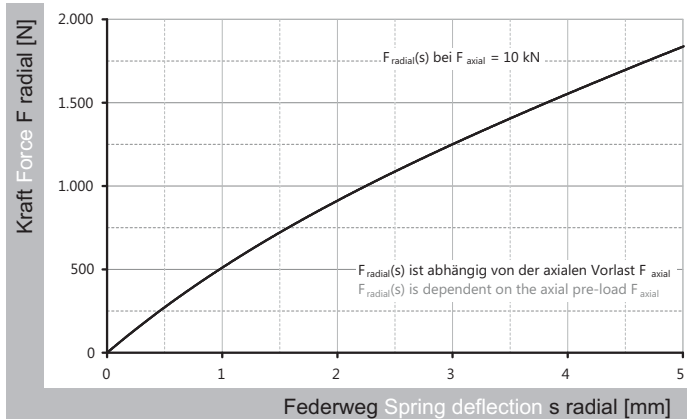
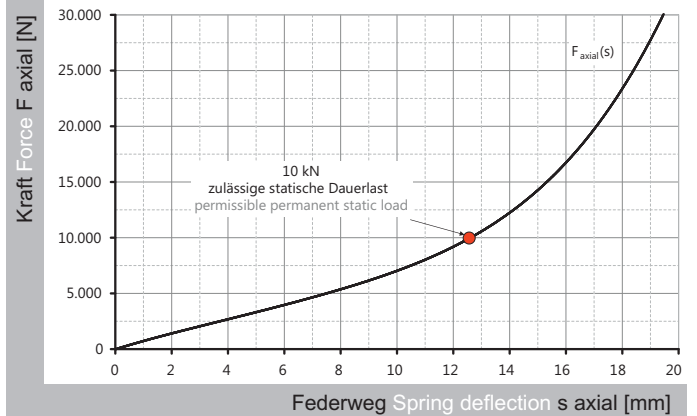

Verlauf der Eigenfrequenz Course of resonant frequency

