

## UH Mount

UH is an antivibration mounting designed to accommodate axial static and shock loads in both directions. The dynamic natural frequency is constant irrespective of the static load.

Mounting type UH is particularly suitable for the suspension of both mobile and static cabs as well as platforms on agricultural vehicles. When fitted with overload/rebound washers, a high strength fail-safe installation is provided.

Moreover, it is possible to alter the characteristics of the mounting by providing a dome-shaped washer at the upper rubber section. This will provide impact resistance to deflection beyond the permissible limit. Effectively isolating vibration and noise, the UH mounting also protects tanks and ancillary equipment against metal fatigue caused by chassis distortion.

### Typical Applications Include:

- Tractors
- Excavators
- Lifting cranes
- Forklift trucks
- Forestry vehicles
- Off-road equipment

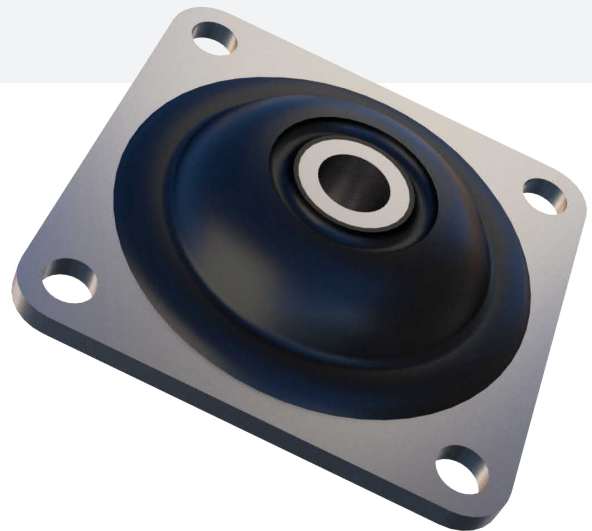

### TECHNICAL DRAWING

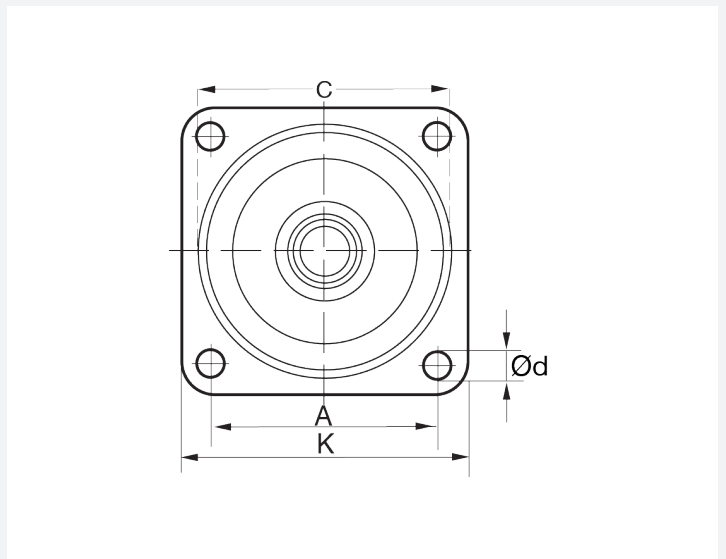
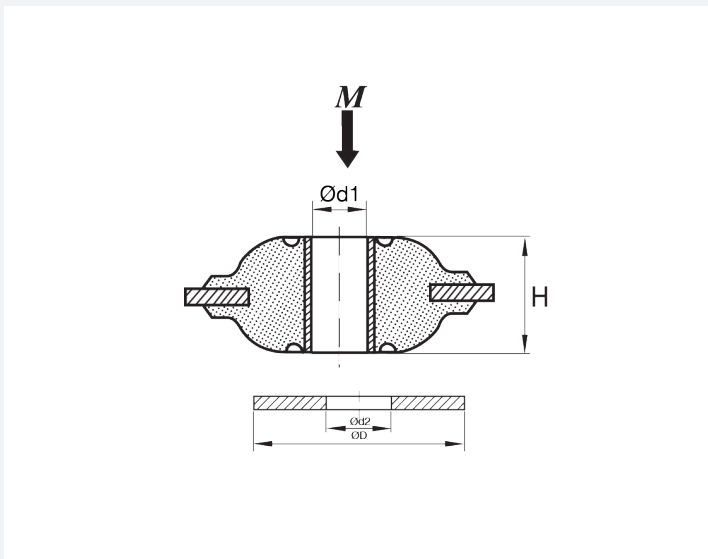

### PRODUCT DATA

TYPE	DRAWING NO.	PART NO.	DIMENSIONS (mm)						MAX. LOAD (kg)	MAX. TORQUE (Nm)	WASHER PART NO.
			K	A	H	C	$\varnothing d$	$\varnothing d_1$			
UH 50	15-4131	10-00086	100.5	80	37	91	10.5	15	250	80	20-00608
UH 70	15-4132	10-00088							400	120	20-00608